

INDUSTRIAL DIESEL ENGINE

**KUBOTA 05 SERIES (3-cylinder)**

# D1305-E3B



## RATED POWER

**21.7kW@3000rpm**

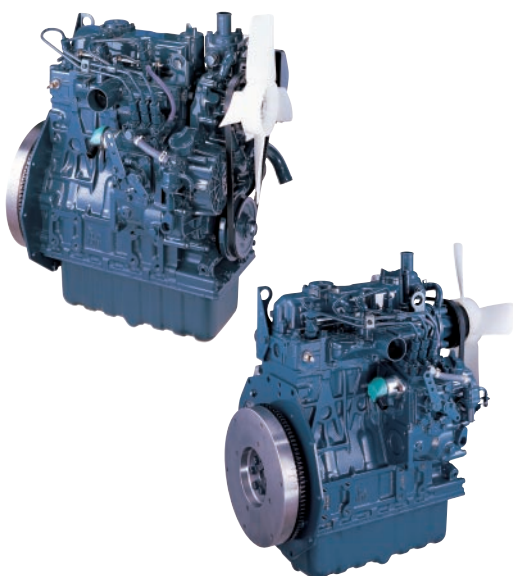

Photographs may show non-standard equipment.

## PERFORMANCE CURVE

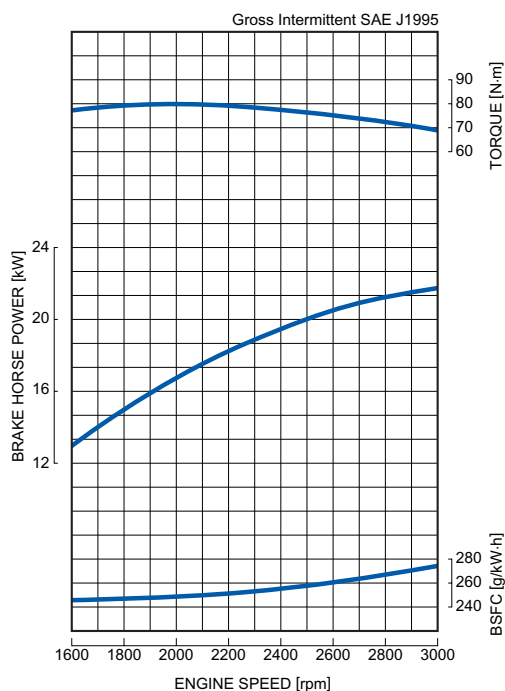

## FEATURES and BENEFITS

### EMISII

Motorul D1305 cu aspiratie naturala (3600rpm) respecta reglementarile EPA Interim Tier 4 care sunt valabile pana in 2012. Acest motor respecta de asemenea standardele EU Stage IIA pe piata europeana.

### PUTERE

Acesta este un motor de mare putere care are cea mai mare iesire, cu aspiratie naturala, in 3 cilindri din seria Kubota 05.

Pasajul de racire dintre cilindru, foloseste tehnologia Kubota si contra-masuri impotriva supraincalzirii, pentru rezistenta si fiabilitate.

### CURAT SI SILENTIOS

Sistemul E-TVCS a fost imbunatatit. Fluxul de aer, camera de combustie si pistonii sunt imbunatatiti sa ofere cu 50% mai putin PM (particule in suspensie).

### OPTIUNE

Exista o varietate mare de optiuni suplimentare pentru motoarele din Seria 05.

## GENERAL SPECIFICATION

Model		<b>D1305-E3B</b>
Emission Regulation		Interim Tier 4 / Stage III A
Type		Vertical 4-cycle Liquid Cooled Diesel
Number of Cylinders		3
Bore	mm (in)	78.0 (3.07)
Stroke	mm (in)	88.0 (3.46)
Displacement	L (cu.in)	1.261 (76.95)
Combustion System		IDI
Intake System		Naturally Aspirated
Maximum Speed	rpm	3000
Output: Gross Intermittent	kW	21.7
	hp	29.1
	ps	29.5
Direction of Rotation		Counterclockwise Viewed on Flywheel
Oil Pan Capacity	L (gal)	5.7 (1.51)
Starter Capacity	V-kW	12-1.2 [US] / 12-1.4 [EU]
Alternator Capacity	V-A	12-40
Length	mm (in)	497.6 (19.59)
Width	mm (in)	396.0 (15.59)
Height (1)	mm (in)	590.1 (23.20)
Height (2)	mm (in)	215.6 (8.49)
Dry Weight	kg (lb)	95.0 (209.4)

\*Specification is subject to change without notice.

\*Output: Gross Intermittent SAE J1995

\*Dry weight is according to Kubota's standard specification.

When specification varies, the weight will vary accordingly.

## DIMENSIONS

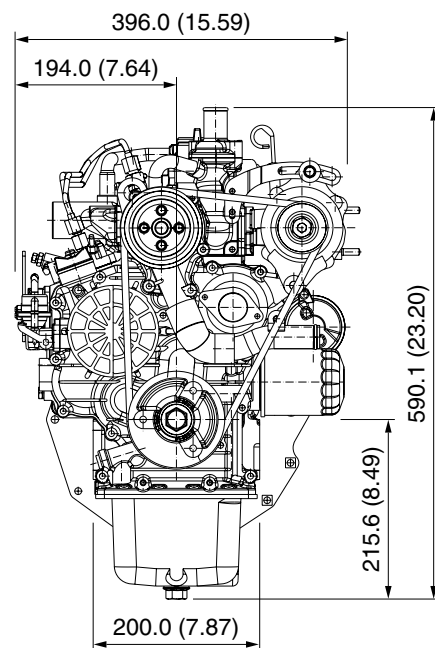
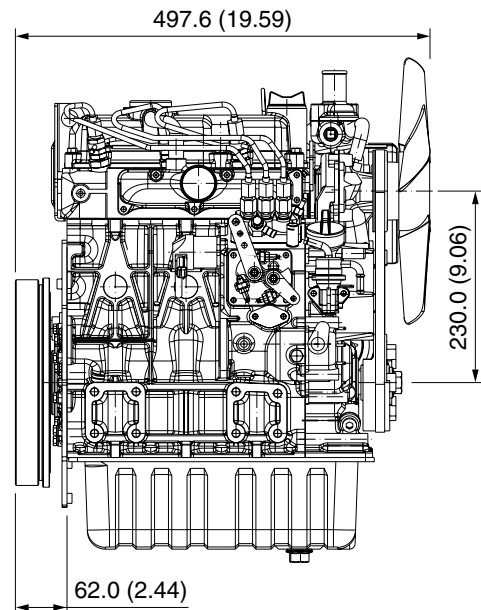

Your Driving Force  
KUBOTA ENGINE

## Mecanexim Engineering

Str. Tudor Arghezi, nr.1, Comuna 1 Decembrie, judetul Ilfov  
Telefon: +40 744 671 621

<http://kubota.com.ro>  
<http://mexanexim.ro>