

INDUSTRIAL DIESEL ENGINE

KUBOTA 03-M SERIES (4-cylinder)

V2003-M-E3B



RATED POWER

32.6kW@2800rpm



Photograph may show non-standard equipment.

PERFORMANCE CURVE

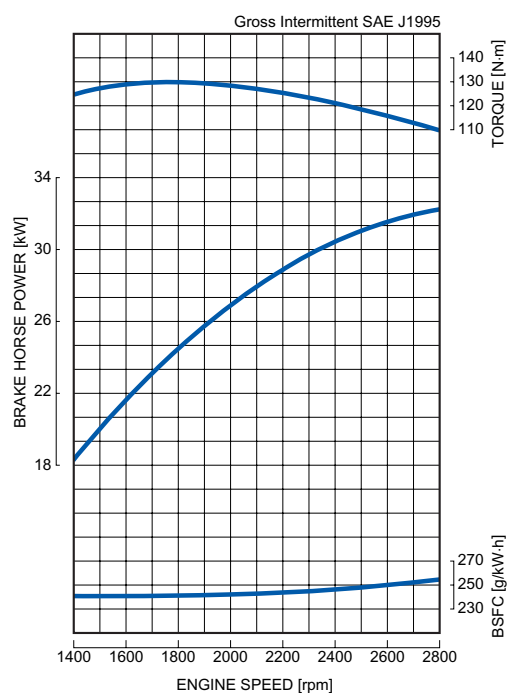

FEATURES and BENEFITS

EMISII

Motorul V2003-M-E3B respecta standardele de emisii EPA Tier 4 care sunt valabile pana in 2012. Acest motor respecta de asemenea standardele EU Stage IIA pe piata europeana.

PUTERE

Motorul este recunoscut pentru aplicatiile industriale. Cu numeroase facilitati, acest motor ofera performanta si flexibilitate.

Pasajul de racire dintre cilindru, foloseste tehnologia Kubota si contra-masuri impotriva supraincalzirii, pentru rezistenta si fiabilitate.

CURAT SI SILENTIOS

Sistemul E-TVCS a fost imbunatatit. Fluxul de aer, camera de combustie si pistonii sunt imbunatatiti sa ofere cu 50% mai putin PM (particule in suspensie).

OPTIUNE

Motoarele din seria 03-M ofera putere laterala take-off PTO, ca raspuns la trend-ul de marire a controlului hidraulic in aplicatiile industriale. Este posibila instalarea unei pompe hidraulice in 2 parti.

GENERAL SPECIFICATION

Model		V2003-M-E3B
Emission Regulation		Interim Tier 4 / Stage III A
Type		Vertical 4-cycle Liquid Cooled Diesel
Number of Cylinders		4
Bore	mm (in)	83 (3.27)
Stroke	mm (in)	92.4 (3.64)
Displacement	L (cu.in)	1.999 (122.0)
Combustion System		IDI
Intake System		Naturally Aspirated
Maximum Speed	rpm	2800
Output: Gross Intermittent	kW	32.6
	hp	43.7
	ps	44.3
Direction of Rotation		Counterclockwise Viewed on Flywheel
Oil Pan Capacity	L (gal)	7.6 (2.01) [US] / 9.5 (2.51) [EU]
Starter Capacity	V-kW	12-1.4
Alternator Capacity	V-A	12-40
Length	mm (in)	667.1 (26.3)
Width	mm (in)	499.0 (19.6)
Height (1)	mm (in)	633.5 (24.9) [US] / 679.0 (26.7) [EU]
Height (2)	mm (in)	220.0 (8.7) [US] / 265.5 (10.5) [EU]
Dry Weight	kg (lb)	180.0 (396.9)

*Specification is subject to change without notice.

*Output: Gross Intermittent SAE J1995

*Dry weight is according to Kubota's standard specification.

When specification varies, the weight will vary accordingly.

DIMENSIONS

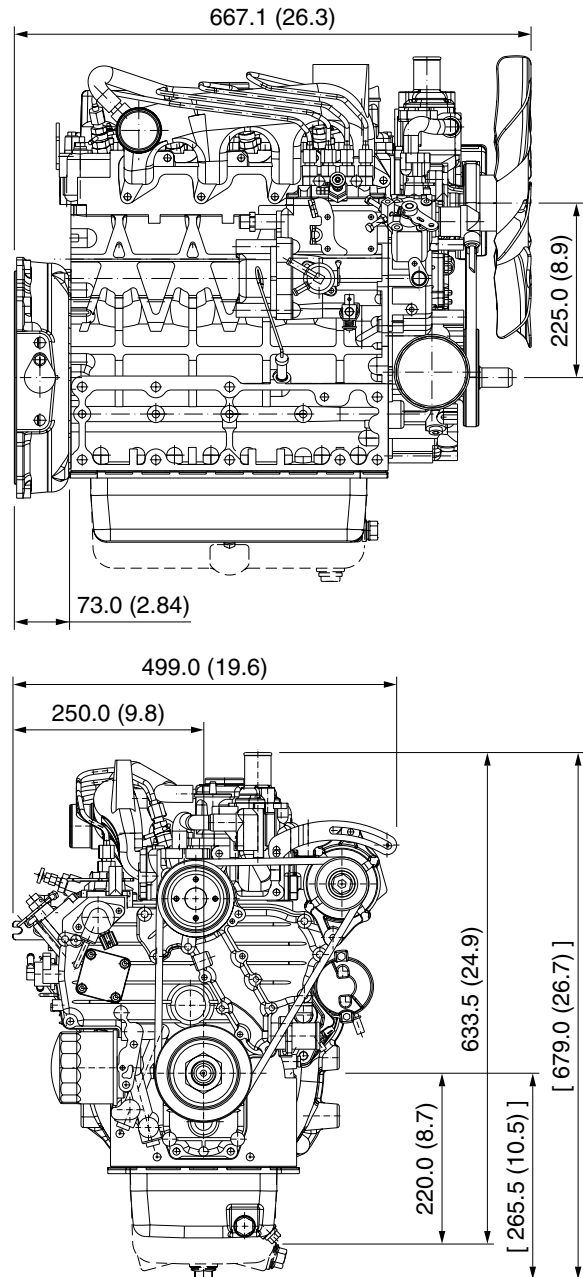

[] EU spec



Your Driving Force
KUBOTA ENGINE

Mecanexim Engineering

Str. Tudor Arghezi, nr.1, Comuna 1 Decembrie, judetul Ilfov
Telefon: +40 744 671 621

<http://kubota.com.ro>

<http://www.mecanexim.ro/>