

INDUSTRIAL DIESEL ENGINE

D1803-CR-TE4B

D1803-CR-TIE4B

KUBOTA 03 SERIES (3-cylinder)

RATED POWER

37.0kW @2700rpm

Photographs may show non-standard equipment.

PERFORMANCE CURVE

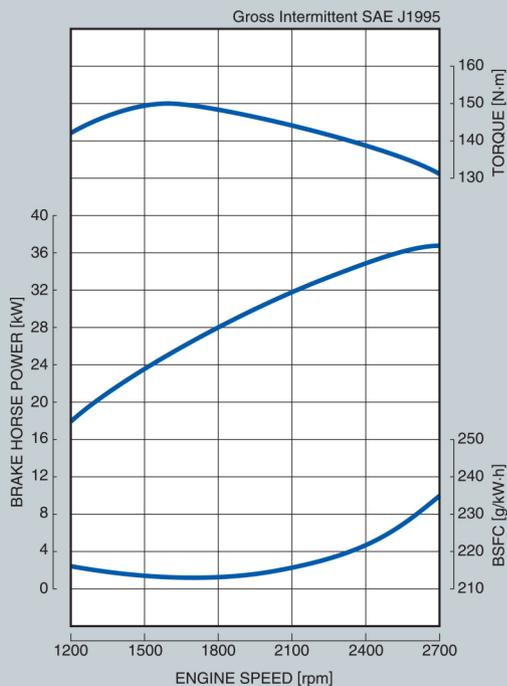

CARACTERISTICI SI BENEFICII

Performanta si tehnologie

Cientii Kubota se asteapta mereu la doua lucruri: performanta puternica si ultimele tehnologii implementate.

Continuam sa oferim excelenta prin respectarea normelor de emisii si prin progresele la noile motoare controlate electronic. Aceste aspecte ofera flexibilitate produselor noastre si serviciilor oferite clientilor din intreaga lume.

Progrese emisii motoare

Motoarele Kubota V3 respecta normele EPA/CARB Tier 4 Final si EU Stage IV. Reducerea noxelor este de 90% in comparatie cu reglementarile impuse.

Pentru a reduce noxele s-a adaptat sistemul "Selective Catalytic Reduction (SCR)", Filtru de particule Diesel (DPF) si "Diesel Oxidation Catalyst (DOC)".

Dezvoltarea si implementarea acestora a dus la respectarea ultimelor reglementari privind emisiile de noxe.

Tehnologia Common Rail

Aceasta a facut posibila optimizarea combustiei si crearea unui motor mult mai durabil, cu un nivel redus de zgomot la functionare si mult mai econom din punct de vedere al combustibilului.

Acestea are incorporat un sistem de auto-curatare performant.

Flexibilitate

Cand lucram cu clienti din diferite tari care au alte cerinte de functionare a motoarelor, flexibilitatea este importanta.

De cand cu motoarele Kubota V3, am evoluat pas cu pas pentru respectarea tuturor cerintelor EPA. Putem pune la dispozitie certificate de atestare a emisiilor pentru orice client din intreaga lume.

Fiabilitate

Motoarele Kubota V3 sunt cea mai buna solutie la nivel global pentru strategia de marketing a companiei dvs. In mod continuu ne dezvoltam pentru a indeplini necesitatile fiecarui client si ne oferim experienta si expertiza de care aveti nevoie.

KUBOTA 03 SERIES D1803-CR-TE4B / D1803-CR-TIE4B

GENERAL SPECIFICATION

Model		D1803-CR-TE4B	D1803-CR-TIE4B
Emission Regulation		Tier4 / Stage III B	
Type		Vertical 4-cycle liquid cooled Diesel	
Number of Cylinders		3	
Bore	mm (in)	87.0 (3.43)	
Stroke	mm (in)	102.4 (4.03)	
Displacement	L (cu.in)	1.826 (111.43)	
Combustion System		DI	
Aspiration		Turbo Charged	Turbo Charged+Turbo After Cooler
Aftertreatment device		DPF+DOC	DOC
Maximum Speed	rpm	2700	
Output: Gross Intermittent	kW	37.0	
	HP	49.6	
	ps	50.3	
Direction of Rotation		Counter clockwise Viewed on Flywheel side	
Oil Pan Capacity	L (U.S.gal)	7.0 (1.85)	
Starter Capacity	V-kW	12-2.0	
Alternator Capacity	V-A	12-60	
Length (A)	mm (in)	758 (29.8)	
Width (B)	mm (in)	513 (20.2)	
Height (C)	mm (in)	735 (28.9)	744 (29.3)
Dry Weight	kg (lb)	196 (432.2)	195 (430.0)

DIMENSIONS

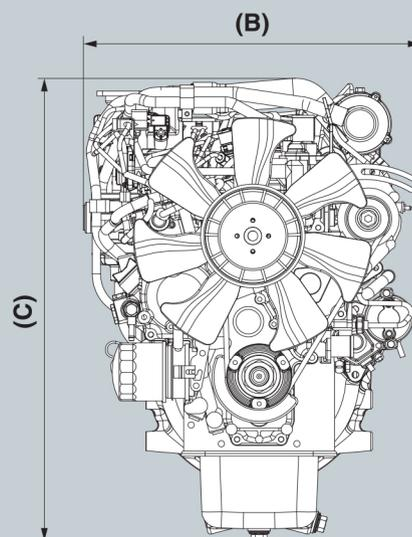
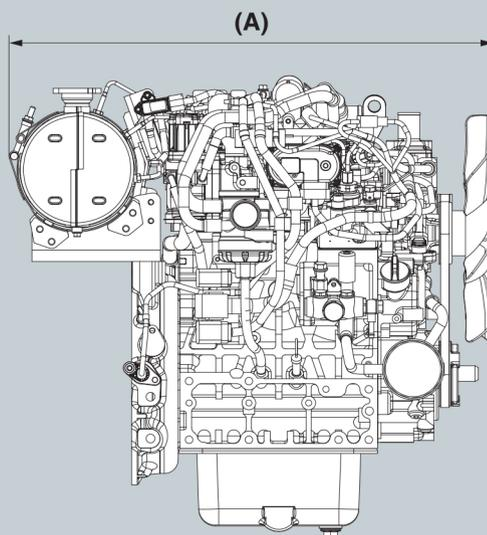

Dimensions and weight depend on completed specifications.

*Specification is subject to change without notice.

*DPF: Diesel Particulate Filter

*DOC: Diesel Oxidation Catalyst

*Output: Gross Intermittent SAE J1995

*Dimensions and dry weight are according to Kubota's standard specification.



Mecanexim Engineering

Str. Tudor Arghezi, nr.1, Comuna 1 Decembrie, judetul Ilfov
Telefon: +40 744 671 621

<http://kubota.com.ro>

<http://www.mecanexim.ro/>