

INDUSTRIAL DIESEL ENGINE

KUBOTA V3 SERIES (4-cylinder)

V3800-TIEF4B

RATED POWER

86.4kW @ 2600rpm



Photographs may show non-standard equipment.

PERFORMANCE CURVES

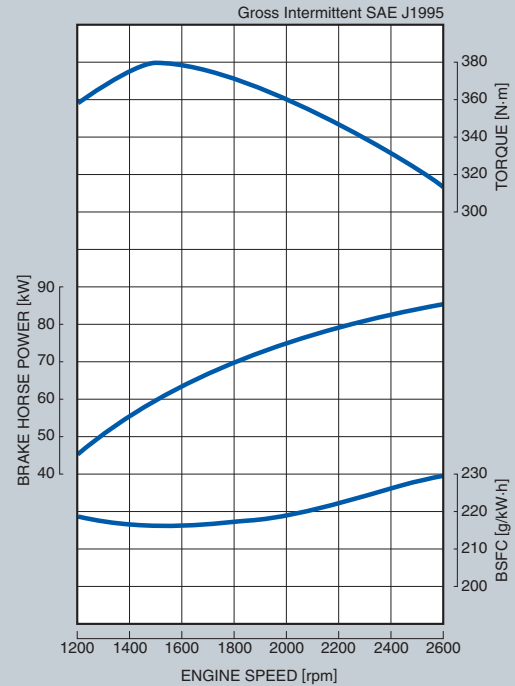

CARACTERISTICI SI BENEFICII

Performanta si tehnologie

Cientii Kubota se asteapta mereu la doua lucruri: performanta puternica si ultimele tehnologii implementate.

Continuam sa oferim excelenta prin respectarea normelor de emisii si prin progresele la noile motoare controlate electronic. Aceste aspecte ofera flexibilitate produselor noastre si serviciilor oferite clientilor din intreaga lume.

Progrese emisii motoare

Motoarele Kubota V3 respecta normele EPA/CARB Tier 4 Final si EU Stage IV. Reducerea noxelor este de 90% in comparatie cu reglementarile impuse.

Pentru a reduce noxele s-a adaptat sistemul "Selective Catalytic Reduction (SCR)", Filtru de particule Diesel (DPF) si "Diesel Oxidation Catalyst (DOC).

Dezvoltarea si implementarea acestora a dus la respectarea ultimelor reglementari privind emisiile de noxe.

Tehnologia Common Rail

Aceasta a facut posibila optimizarea combustiei si crearea unui motor mult mai durabil, cu un nivel redus de zgomot la functionare si mult mai econom din punct de vedere al combustibilului.

Acestea are incorporat un sistem de auto-curatare performant.

Flexibilitate

Cand lucram cu clienti din diferite tari care au alte cerinte de functionare a motoarelor, flexibilitatea este importanta.

De cand cu motoarele Kubota V3, am evoluat pas cu pas pentru respectarea tuturor cerintelor EPA. Putem pune la dispozitie certificate de atestare a emisiilor pentru orice client din intreaga lume.

Fiabilitate

Motoarele Kubota V3 sunt cea mai buna solutie la nivel global pentru strategia de marketing a companiei dvs. In mod continuu ne dezvoltam pentru a indeplini necesitatile fiecarui client si ne oferim experienta si expertiza de care aveti nevoie.

KUBOTA V3 SERIES V3800-TIEF4B

GENERAL SPECIFICATIONS

Model		V3800-TIEF4B
Emission Regulation		Tier 4 Final / Stage IV
Type		Vertical 4-cycle liquid cooled Diesel
Number of Cylinders		4
Bore	mm (in)	100 (3.94)
Stroke	mm (in)	120 (4.72)
Displacement	L (cu.in)	3.769 (230.0)
Combustion System		DI
Aspiration		Turbo charged + Turbo After Cooler
Aftertreatment device		DOC+DPF+SCR
Maximum Speed	rpm	2600
Output: Gross Intermittent	kW	86.4
	HP	115.8
	ps	117.4
Direction of Rotation		Counter clockwise Viewed from Flywheel side
Oil Pan Capacity	L (U.S.gal)	13.2 (3.49)
Starter Capacity	V-kW	12-3.0
Alternator Capacity	V-A	12-100
Length	mm (in)	889 (35.0)
Width	mm (in)	718 (28.3)
Height	mm (in)	1256 (49.4)
Dry Weight	kg (lb)	400 (881.8)

*Specification is subject to change without notice.

*DOC: Diesel Oxidation Catalyst

*DPF: Diesel Particulate Filter

*SCR: Selective Catalytic Reduction

*Output: Gross Intermittent SAE J1995

*Dimensions and dry weight are according to Kubota's standard specification.

DIMENSIONS

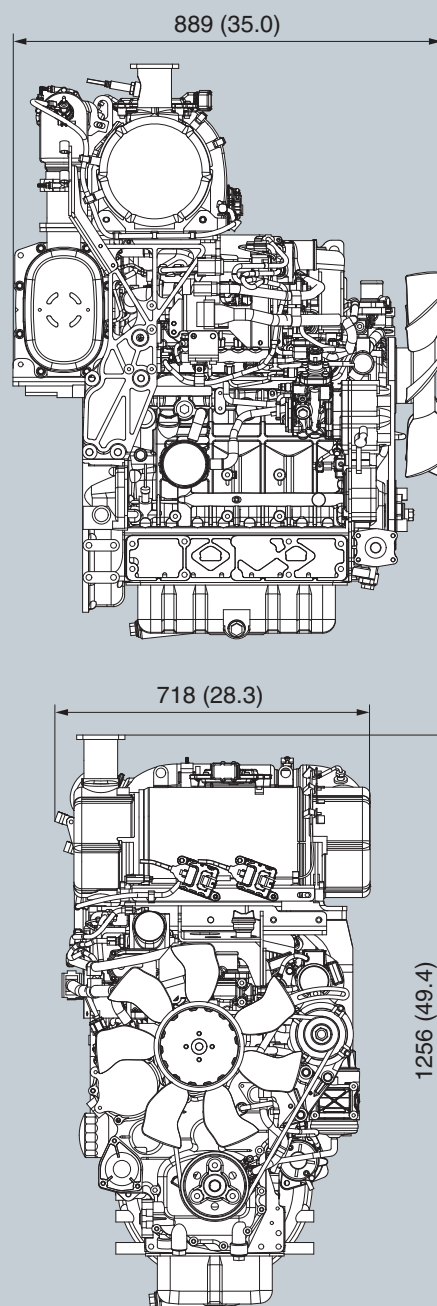

Dimensions and weight depend on completed specifications.



Mecanexim Engineering

Str. Tudor Arghezi, nr.1, Comuna 1 Decembrie, judetul Ilfov
Telefon: +40 744 671 621

<http://kubota.com.ro>

<http://www.mecanexim.ro/>