

# WG/DF752

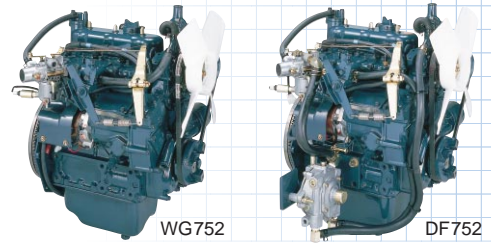

## Dimensions mm(in.)

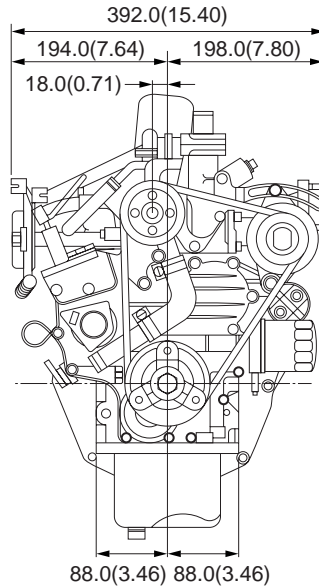
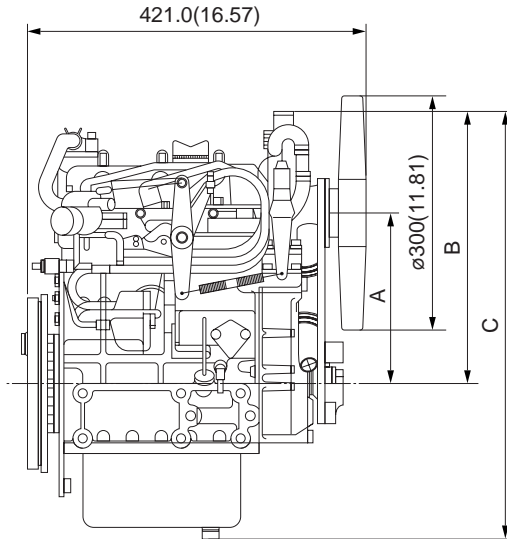

	A	B	C
High Fan Position	215(8.46)	344(13.54)	540(21.26)
Low Fan Position	175(6.89)	305(12.01)	501(19.72)

Shown above: with Kubota Standard flywheel and rear-end-plate.  
Option kit for Clutch No.6 1/2" Flywheel and SAE No.5 Flywheel Housing is also available.

## Specifications

Model		WG752	DF752
Type	mm (in.)	Vertical, Liquid-Cooled	Vertical, Liquid-Cooled
	L (cu.in.)	4-cycle Gasoline engine	4-cycle engine
Cylinders		3	
Bore x Stroke	mm (in.)	68 x 68 (2.68 x 2.68)	
Displacement	L (cu.in.)	0.740 (45.2)	
Output	Gross intermittent	18.3/24.5/24.9/3600	17.5/23.5/23.8/3600
	Net intermittent	17.1/23.0/23.3/3600	16.4/22.0/22.3/3600
	Net Continuous	13.4/18.0/18.2/3600	12.7/17.0/17.3/3600
No Load High Idling Speed	rpm	3850	
No Load Low Idling Speed	rpm	1500	
Max. Torque	N-m(lbs ft) /rpm	54.9(40.5)/2400	52.0(38.3)/2400
Fuel		Unleaded gasoline	*Commercial LPG
Lubricating System		Forced lubricating by trochoid pump	
Lubricating Oil		Quality better than SH class	
Cooling system		Radiator (Not included in the basic specification)	
Starter Capacity	V-kW	12-0.7	
Alternator Capacity	V-W	12-150	
Dry Weight	kg (lbs.)	61.7 (136.0)	
Dimensions (L x W x H)	High Fan Position	421.0 x 392.0 x 540.0 (16.57 x 15.44 x 21.26)	
	Low Fan Position	421.0 x 392.0 x 501.0 (16.57 x 15.44 x 19.72)	
Direction of Rotation		Counterclockwise (viewed from the flywheel side)	

## Performance Curve

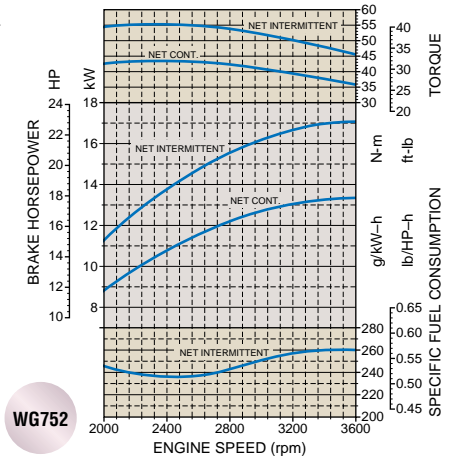

WG752

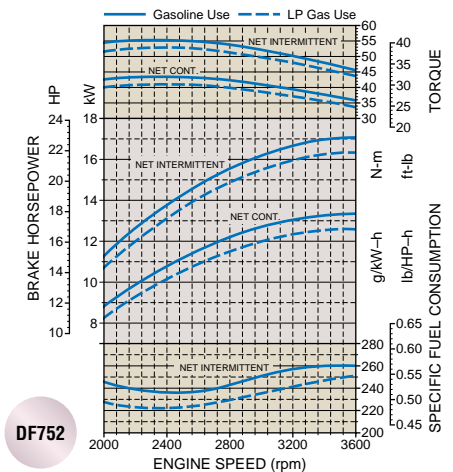

DF752

Mecanexim Engineering

Str. Tudor Arghezi, nr.1, Comuna 1 Decembrie, judetul Ilfov  
Telefon: +40 744 671 621

<http://kubota.com.ro>

<http://www.mecanexim.ro/>